

LTR	DESCRIPTION	DATE	BY
-	Released	8/20/03	JCL

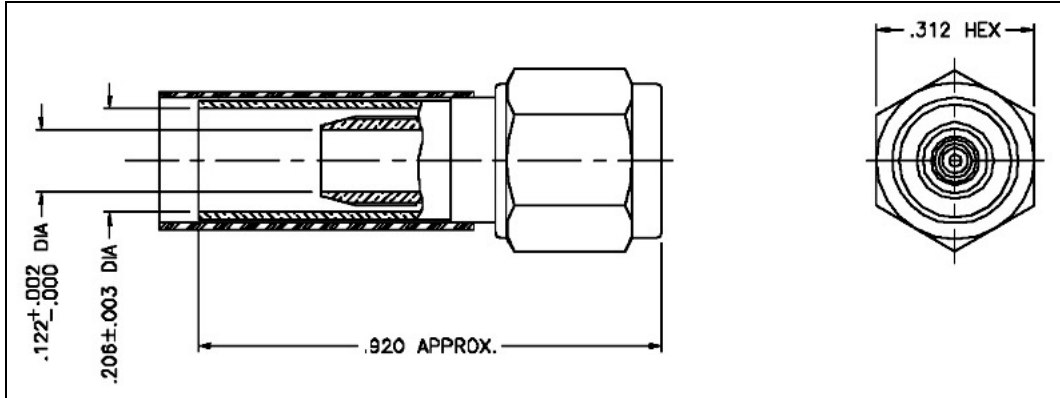

**I. MATERIALS & FINISHES**

- center contact: Gold Plated Brass (solder-pin)
- outer contact: Stainless Steel
- body: Stainless Steel
- coupling nut: Stainless Steel
- crimp sleeve: Stainless Steel
- dielectric: Teflon® PTFE
- gasket: Silicone Rubber
- shrink sleeve: Adhesive Lined Polyolefin
- attachment: braid crimp (.213" hex)

**II. ELECTRICAL PROPERTIES**

- impedance: 50 ohms
- working voltage: 750 vrms (max)
- vswr: 1.25:1 (max) up to 2.5 GHz
- insertion loss: 0.10 x √Fghz

Unless otherwise specified, dimensions are in inches. Tolerances are applicable when specified.

These drawings and specifications contain proprietary information which is the property of Times Microwave Systems.

Approvals		
Drawn	JCL	8/20/03

**TIMES MICROWAVE SYSTEMS**  
 Wallingford, CT 06492  
 (203) 949-8400; (203) 949-8423.Fax  
 www.timesmicrowave.com

**TC-195-SM**  
**SMA Male (Plug)**  
**for LMR-195Cable**

Size A	CAGE CODE <b>68999</b>	Drawing No.: <b>3190-1553</b>
--------	---------------------------	----------------------------------