

**TIMES** MICROWAVE SYSTEMS

## *EZ-200-NM (stock code: 3190-1475) Type N Plug*

*Non-solder center contact  
Crimp-on (.213" hex.) outer contact*

### **INSTALLATION INSTRUCTIONS**

*(Cable Types: LMR-200 and Variants)  
(Cable Types: LMR-195 and Variants)*

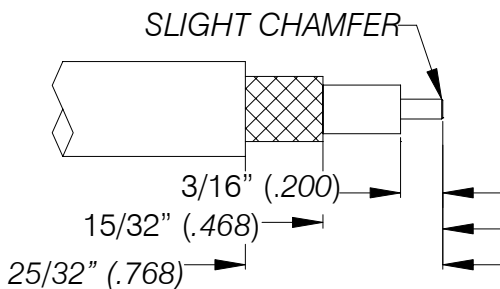

1. (A) Trim cable to dimensions shown.  
(B) Remove any residual plastic from center conductor.  
(C) Deburr center conductor using a fine file or Times DBT-01 tool.

STEP 1

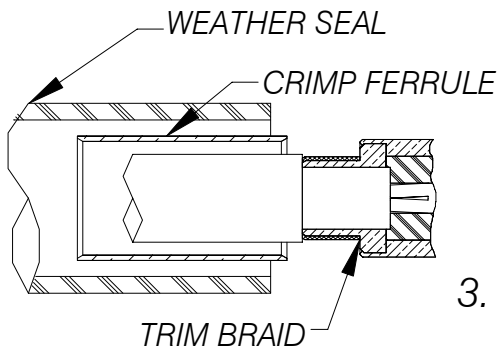

2. (A) Slide weather seal and crimp ferrule over cable.  
(B) Flare braid and insert cable into connector body until dielectric is seated, all braid wires outside of body, foil tape inside of body, and center conductor is inserted fully into connector center pin.  
(C) Trim excess braid flush to shoulder on connector.

STEP 2

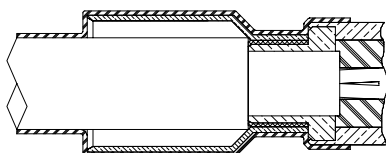

3. (A) Slide crimp ferrule over braid and crimp as close to body as possible using a .213 hex die in a Times HX-4 crimp tool or equivalent. Do not crimp rear of crimp ferrule.  
(B) Heat shrink weather seal over rear of connector body and down on to cable jacket using hot air gun.

STEP 3

Rev B