

TIMES MICROWAVE SYSTEMS

TC-240-NMH-D (stock code: 3190-382)

Type N Plug yy/mm

Solder-on center contact

Crimp-on (.255" hex.) outer contact

INSTALLATION INSTRUCTIONS

(Cable Types: LMR-240; 240 DB; 240 FR; 240 MA; 240 Ultraflex)

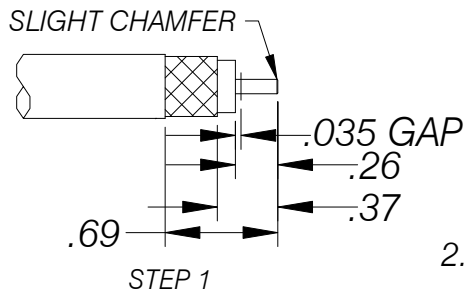

1. (A) Trim cable to dimensions shown using razor knife.
(B) Remove any residual plastic from center conductor.
(C) Deburr center conductor using a fine file.

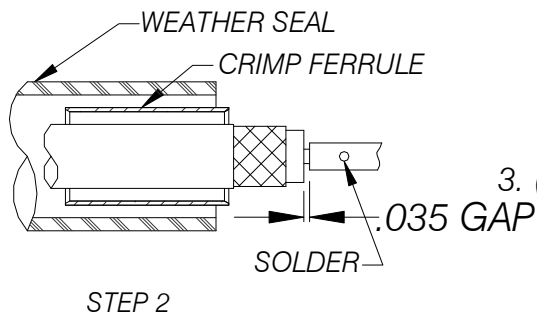

2. (A) Slide weather seal and crimp ferrule over cable.
(B) Seat center contact onto conductor leaving .035 in gap and solder cable to conductor. Use minimal heat to minimize melting of foam dielectric. Inspect to be sure aluminum foil is not touching center contact.

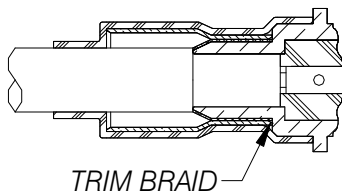

3. (A) Flare braid and insert cable into connector body until center contact snaps into position with all braid wires on outside of connector body and aluminum tape inside connector body.
(B) Trim excess braid flush to shoulder on connector
(C) Slide crimp ring over braid and crimp as close to body as possible using a .255 hex in a Times HX-4 crimp tool or equivalent. Do not crimp rear of sleeve
(D) Heat shrink weather seal over rear of connector body and down onto connector jacket using hot air gun.

Rev. B