

**TIMES** MICROWAVE SYSTEMS

**TC-240-NF-BH (stock code: 3190-419)**

*Type N-Female Jack Bulkhead*

*Solder-on center contact*

*Crimp-on (.255" hex.) outer contact*

## INSTALLATION INSTRUCTIONS

*(Cable Types: LMR-240; 240 DB; 240 FR; 240 MA; 240 Ultraflex )*

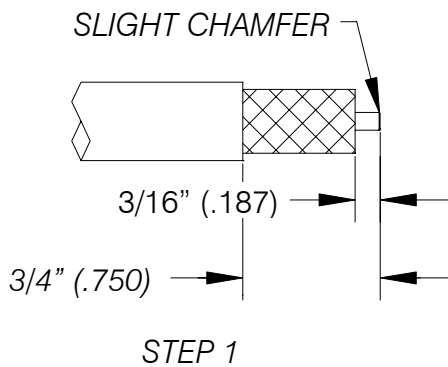

1. (A) Trim cable to dimensions shown.  
(B) Remove any residual plastic from center conductor.  
(C) Deburr center conductor using a fine file or Times DBT-01 tool.

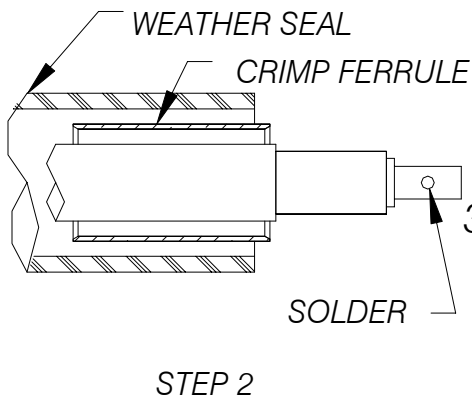

2. (A) Slide weather seal and crimp ferrule over cable.  
(B) Seat center contact firmly against cable dielectric and solder contact cable to conductor. Use minimal heat to minimize melting of foam dielectric. Inspect to be sure aluminum foil is not touching center contact.

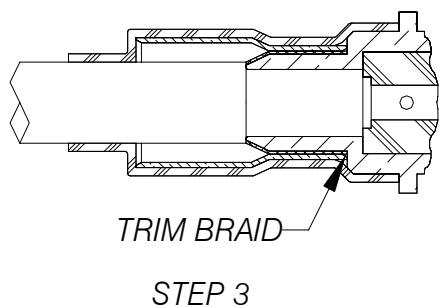

3. (A) Flare braid and insert cable into connector body until dielectric is seated with all braid wires on outside of connector body and aluminum tape inside connector body.  
(B) Trim excess braid flush to shoulder on connector.  
(C) Slide crimp ferrule over braid and crimp as close to body as possible using a .255 hex. die in a Times HX-4 crimp tool or equivalent. Do not crimp rear of crimp ferrule.  
(D) Heat shrink weather seal over rear of connector body and down on to cable jacket using hot air gun.

Rev. A